



## Features

- Low power consumption
- Low voltage drop
- Low temperature coefficient
- High input voltage (up to 15V)
- Output voltage accuracy: tolerance  $\pm 2\%$
- TO92, SOT89, SOT23-3 and SOT23 package

## Applications

- Battery-powered equipment
- Communication equipment
- Audio/Video equipment

## General Description

The TX75XXM series is a set of three-terminal low power high voltage regulators implemented in CMOS technology. They allow input voltages as high as 15V. They are available with several fixed output voltages ranging from 2.1V to 6.0V. CMOS

technology ensures low voltage drop and low quiescent current. Although designed primarily as fixed voltage regulators, these devices can be used with external components to obtain variable voltages and currents.

## Selection Table

Part No.	Output Voltage	Package	Marking
TX7521Mxx	2.1V	TO92 SOT89 SOT23-3 SOT23	75XXA-1(for TO92) 75XX-1(for SOT89) HTXX(for SOT23-3) HTXX(for SOT23)
TX7522Mxx	2.2V		
TX7523Mxx	2.3V		
TX7525Mxx	2.5V		
TX7527Mxx	2.7V		
TX7530Mxx	3.0V		
TX7533Mxx	3.3V		
TX7536Mxx	3.6V		
TX7540Mxx	4.0V		
TX7544Mxx	4.4V		
TX7545Mxx	4.5V		
TX7550Mxx	5.0V		
TX7560Mxx	6.0V		

Note: "XX" stands for output voltages.

## Order Information

TX75①②③④⑤

Designator	Symbol	Description
① ②	Integer	Output Voltage(2.1~6.0V)
③	M	Standard
④	T	Package:TO-92
	P	Package:SOT89
	M	Package:SOT23-3
	N	Package:SOT23
⑤	R	RoHS / Pb Free



G Halogen Free

### Block Diagram

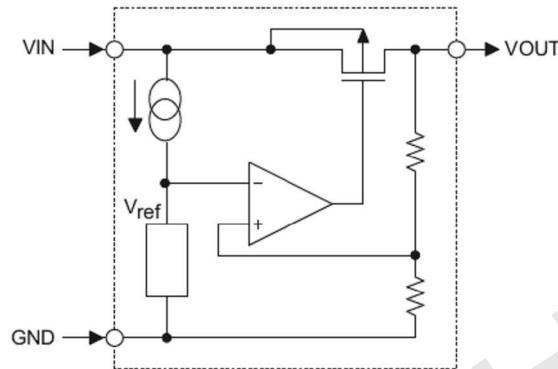

### Pin Assignment

TO92 (Front view)



SOT89 (Top view)



SOT23-3 and SOT23 (Top view)

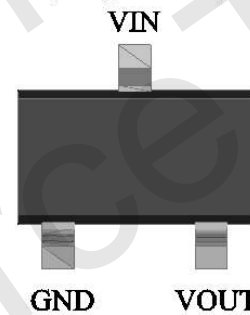

### Absolute Maximum Ratings

Supply Voltage .....-0.3V to 18V      Storage Temperature .....-50°C to 125°C  
Operating Temperature .....-40°C to 85°C

Note: These are stress ratings only. Stresses exceeding the range specified under “Absolute Maximum Ratings” may cause substantial damage to the device. Functional operation of this device at other conditions beyond those listed in the specification is not implied and prolonged exposure to extreme conditions may affect device reliability.

### Thermal Information

Symbol	Parameter	Package	Max.	Unit
$\theta_{JA}$	Thermal Resistance (Junction to Ambient) (Assume no ambient airflow, no heat sink)	TO92	200	°C/W
		SOT89	200	°C/W
		SOT23-3	500	°C/W
$P_D$	Power Dissipation	TO92	0.50	W
		SOT89	0.50	W
		SOT23-3	0.20	W

Note:  $P_D$  is measured at  $T_a = 25^\circ\text{C}$



## Electrical Characteristics

### TX7521Mxx, +2.1V Output Type

Symbol	Parameter	Test Conditions		Min.	Typ.	Max.	Unit
		V <sub>IN</sub>	Conditions				
V <sub>OUT</sub>	Output Voltage	4.1V	I <sub>OUT</sub> =10mA	2.058	2.100	2.142	V
I <sub>OUT</sub>	Output Current	4.1V	-	120	150	-	mA
ΔV <sub>OUT</sub>	Load Regulation	4.1V	1mA ≤ I <sub>OUT</sub> ≤ 50mA	-	60	150	mV
V <sub>DIF</sub>	Voltage Drop(Note)	-	I <sub>OUT</sub> =1mA, ΔV <sub>OUT</sub> =2%	-	50	-	mV
I <sub>SS</sub>	Current Consumption	4.1V	No load	-	1.5	2	μA
$\frac{V_{OUT}}{V_{IN} - V_{OUT}}$	Line Regulation	-	3.1V ≤ V <sub>IN</sub> ≤ 16V I <sub>OUT</sub> =1mA	-	0.2	-	%/V
V <sub>IN</sub>	Input Voltage	-	-	-	-	15	V
$\frac{V_{OUT}}{Ta}$	Temperature Coefficient	4.1V	I <sub>OUT</sub> =10mA 0°C < Ta < 70°C	-	±0.37	-	mV/°C

Note: Dropout voltage is defined as the input voltage minus the output voltage that produces a 2% change in the output voltage from the value at V<sub>IN</sub> = V<sub>OUT</sub>+2V with a fixed load.

### TX7523Mxx, +2.3V Output Type

Symbol	Parameter	Test Conditions		Min.	Typ.	Max.	Unit
		V <sub>IN</sub>	Conditions				
V <sub>OUT</sub>	Output Voltage	4.3V	I <sub>OUT</sub> =10mA	2.254	2.300	2.346	V
I <sub>OUT</sub>	Output Current	4.3V	-	120	150	-	mA
ΔV <sub>OUT</sub>	Load Regulation	4.3V	1mA ≤ I <sub>OUT</sub> ≤ 50mA	-	60	150	mV
V <sub>DIF</sub>	Voltage Drop(Note)	-	I <sub>OUT</sub> =1mA, ΔV <sub>OUT</sub> =2%	-	50	-	mV
I <sub>SS</sub>	Current Consumption	4.3V	No load	-	1.5	2	μA
$\frac{V_{OUT}}{V_{IN} - V_{OUT}}$	Line Regulation	-	3.3V ≤ V <sub>IN</sub> ≤ 16V I <sub>OUT</sub> =1mA	-	0.2	-	%/V
V <sub>IN</sub>	Input Voltage	-	-	-	-	15	V
$\frac{V_{OUT}}{Ta}$	Temperature Coefficient	4.3V	I <sub>OUT</sub> =10mA 0°C < Ta < 70°C	-	±0.39	-	mV/°C

Note: Dropout voltage is defined as the input voltage minus the output voltage that produces a 2% change in the output voltage from the value at V<sub>IN</sub> = V<sub>OUT</sub>+2V with a fixed load.



**TX7525Mxx, +2.5V Output Type**

Symbol	Parameter	Test Conditions		Min.	Typ.	Max.	Unit
		V <sub>IN</sub>	Conditions				
V <sub>OUT</sub>	Output Voltage	4.5V	I <sub>OUT</sub> =10mA	2.45	2.500	2.55	V <sub>A</sub>
I <sub>OUT</sub>	Output Current	4.5V	-	120	150	-	mV
ΔV <sub>OUT</sub>	Load Regulation	4.5V	1mA ≤ I <sub>OUT</sub> ≤ 50mA	-	60	150	mV
V <sub>DIF</sub>	Voltage Drop(Note)	-	I <sub>OUT</sub> =1mA, ΔV <sub>OUT</sub> =2%	-	50	-	mV
I <sub>SS</sub>	Current Consumption	4.5V	No load	-	1.5	2	μ
$\frac{V_{OUT}}{V_{IN} \cdot V_{OUT}}$	Line Regulation	-	3.5V ≤ V <sub>IN</sub> ≤ 16V I <sub>OUT</sub> =1mA	-	0.2	-	%
V <sub>IN</sub>	Input Voltage	-	-	-	-	15	V
$\frac{V_{OUT}}{T_a}$	Temperature Coefficient	4.5V	I <sub>OUT</sub> =10mA 0°C < T <sub>a</sub> < 70°C	-	±0.41	-	mV/°C

Note: Dropout voltage is defined as the input voltage minus the output voltage that produces a 2% change in the output voltage from the value at V<sub>IN</sub> = V<sub>OUT</sub>+2V with a fixed load.

**TX7527Mxx, +2.7V Output Type**

Symbol	Parameter	Test Conditions		Min.	Typ.	Max.	Unit
		V <sub>IN</sub>	Conditions				
V <sub>OUT</sub>	Output Voltage	4.7V	I <sub>OUT</sub> =10mA	2.646	2.700	2.754	V <sub>A</sub>
I <sub>OUT</sub>	Output Current	4.7V	-	120	150	-	mV
ΔV <sub>OUT</sub>	Load Regulation	4.7V	1mA ≤ I <sub>OUT</sub> ≤ 50mA	-	60	150	mV
V <sub>DIF</sub>	Voltage Drop(Note)	-	I <sub>OUT</sub> =1mA, ΔV <sub>OUT</sub> =2%	-	50	-	mV
I <sub>SS</sub>	Current Consumption	4.7V	No load	-	1.5	2	μ
$\frac{V_{OUT}}{V_{IN} \cdot V_{OUT}}$	Line Regulation	-	3.7V ≤ V <sub>IN</sub> ≤ 16V I <sub>OUT</sub> =1mA	-	0.2	-	%
V <sub>IN</sub>	Input Voltage	-	-	-	-	15	V
$\frac{V_{OUT}}{T_a}$	Temperature Coefficient	4.7V	I <sub>OUT</sub> =10mA 0°C < T <sub>a</sub> < 70°C	-	±0.43	-	mV/°C

Note: Dropout voltage is defined as the input voltage minus the output voltage that produces a 2% change in the output voltage from the value at V<sub>IN</sub> = V<sub>OUT</sub>+2V with a fixed load.



**TX7530Mxx, +3.0V Output Type**

Symbol	Parameter	Test Conditions		Min.	Typ.	Max.	Unit
		V <sub>IN</sub>	Conditions				
V <sub>OUT</sub>	Output Voltage	5V	I <sub>OUT</sub> =10mA	2.94	3.00	3.06	V
I <sub>OUT</sub>	Output Current	5V	-	120	150	-	mA
ΔV <sub>OUT</sub>	Load Regulation	5V	1mA ≤ I <sub>OUT</sub> ≤ 50mA	-	60	150	mV
V <sub>DIF</sub>	Voltage Drop(Note)	-	I <sub>OUT</sub> =1mA, ΔV <sub>OUT</sub> =2%	-	50	-	mV
I <sub>SS</sub>	Current Consumption	5V	No load	-	1.5	2	μA
$\frac{V_{OUT}}{V_{IN} - V_{OUT}}$	Line Regulation	-	4V ≤ V <sub>IN</sub> ≤ 16V I <sub>OUT</sub> =1mA	-	0.2	-	%/V
V <sub>IN</sub>	Input Voltage	-	-	-	-	15	V
$\frac{V_{OUT}}{T_a}$	Temperature Coefficient	5V	I <sub>OUT</sub> =10mA 0°C < T <sub>a</sub> < 70°C	-	±0.45	-	mV/°C

Note: Dropout voltage is defined as the input voltage minus the output voltage that produces a 2% change in the output voltage from the value at V<sub>IN</sub> = V<sub>OUT</sub>+2V with a fixed load.

**TX7533Mxx, +3.3V Output Type**

Symbol	Parameter	Test Conditions		Min.	Typ.	Max.	Unit
		V <sub>IN</sub>	Conditions				
V <sub>OUT</sub>	Output Voltage	5.3V	I <sub>OUT</sub> =10mA	3.234	3.300	3.366	V
I <sub>OUT</sub>	Output Current	5.3V	-	120	150	-	mA
ΔV <sub>OUT</sub>	Load Regulation	5.3V	1mA ≤ I <sub>OUT</sub> ≤ 50mA	-	60	150	mV
V <sub>DIF</sub>	Voltage Drop(Note)	-	I <sub>OUT</sub> =1mA, ΔV <sub>OUT</sub> =2%	-	50	-	mV
I <sub>SS</sub>	Current Consumption	5.3V	No load	-	1.5	2	μA
$\frac{V_{OUT}}{V_{IN} - V_{OUT}}$	Line Regulation	-	4.5V ≤ V <sub>IN</sub> ≤ 16V I <sub>OUT</sub> =1mA	-	0.2	-	%/V
V <sub>IN</sub>	Input Voltage	-	-	-	-	15	V
$\frac{V_{OUT}}{T_a}$	Temperature Coefficient	5.3V	I <sub>OUT</sub> =10mA 0°C < T <sub>a</sub> < 70°C	-	±0.5	-	mV/°C

Note: Dropout voltage is defined as the input voltage minus the output voltage that produces a 2% change in the output voltage from the value at V<sub>IN</sub> = V<sub>OUT</sub>+2V with a fixed load.



**TX7536Mxx, +3.6V Output Type**

Symbol	Parameter	Test Conditions		Min.	Typ.	Max.	Unit
		V <sub>IN</sub>	Conditions				
V <sub>OUT</sub>	Output Voltage	5.6V	I <sub>OUT</sub> =10mA	3.528	3.600	3.672	V
I <sub>OUT</sub>	Output Current	5.6V	-	120	150	-	mA
ΔV <sub>OUT</sub>	Load Regulation	5.6V	1mA ≤ I <sub>OUT</sub> ≤ 50mA	-	60	150	mV
V <sub>DIF</sub>	Voltage Drop(Note)	-	I <sub>OUT</sub> =1mA, ΔV <sub>OUT</sub> =2%	-	50	-	mV
I <sub>SS</sub>	Current Consumption	5.6V	No load	-	1.5	2.0	μA
$\frac{V_{OUT}}{V_{IN} - V_{OUT}}$	Line Regulation	-	4.6V ≤ V <sub>IN</sub> ≤ 16V I <sub>OUT</sub> =1mA	-	0.2	-	%/V
V <sub>IN</sub>	Input Voltage	-	-	-	-	15	V
$\frac{V_{OUT}}{T_a}$	Temperature Coefficient	5.6V	I <sub>OUT</sub> =10mA 0°C < T <sub>a</sub> < 70°C	-	±0.6	-	mV/°C

Note: Dropout voltage is defined as the input voltage minus the output voltage that produces a 2% change in the output voltage from the value at V<sub>IN</sub> = V<sub>OUT</sub>+2V with a fixed load.

**TX7540Mxx, +4.0V Output Type**

Symbol	Parameter	Test Conditions		Min.	Typ.	Max.	Unit
		V <sub>IN</sub>	Conditions				
V <sub>OUT</sub>	Output Voltage	6.0V	I <sub>OUT</sub> =10mA	3.920	4.000	4.080	V
I <sub>OUT</sub>	Output Current	6.0V	-	120	150	-	mA
ΔV <sub>OUT</sub>	Load Regulation	6.0V	1mA ≤ I <sub>OUT</sub> ≤ 50mA	-	60	150	mV
V <sub>DIF</sub>	Voltage Drop(Note)	-	I <sub>OUT</sub> =1mA, ΔV <sub>OUT</sub> =2%	-	50	-	mV
I <sub>SS</sub>	Current Consumption	6.0V	No load	-	1.5	2.0	μA
$\frac{V_{OUT}}{V_{IN} - V_{OUT}}$	Line Regulation	-	5V ≤ V <sub>IN</sub> ≤ 16V I <sub>OUT</sub> =1mA	-	0.2	-	%/V
V <sub>IN</sub>	Input Voltage	-	-	-	-	15	V
$\frac{V_{OUT}}{T_a}$	Temperature Coefficient	6.0V	I <sub>OUT</sub> =10mA 0°C < T <sub>a</sub> < 70°C	-	±0.6	-	mV/°C

Note: Dropout voltage is defined as the input voltage minus the output voltage that produces a 2% change in the output voltage from the value at V<sub>IN</sub> = V<sub>OUT</sub>+2V with a fixed load.



**TX7544Mxx, +4.4V Output Type**

Symbol	Parameter	Test Conditions		Min.	Typ.	Max.	Unit
		V <sub>IN</sub>	Conditions				
V <sub>OUT</sub>	Output Voltage	6.4V	I <sub>OUT</sub> =10mA	4.312	4.400	4.488	V
I <sub>OUT</sub>	Output Current	6.4V	-	120	150	-	mA
ΔV <sub>OUT</sub>	Load Regulation	6.4V	1mA ≤ I <sub>OUT</sub> ≤ 50mA	-	60	150	mV
V <sub>DIF</sub>	Voltage Drop(Note)	-	I <sub>OUT</sub> =1mA, ΔV <sub>OUT</sub> =2%	-	50	-	mV
I <sub>SS</sub>	Current Consumption	6.4V	No load	-	1.5	2.0	μA
$\frac{V_{OUT}}{V_{IN} - V_{OUT}}$	Line Regulation	-	5.4V ≤ V <sub>IN</sub> ≤ 16V I <sub>OUT</sub> =1mA	-	0.2	-	%/V
V <sub>IN</sub>	Input Voltage	-	-	-	-	15	V
$\frac{V_{OUT}}{T_a}$	Temperature Coefficient	6.4V	I <sub>OUT</sub> =10mA 0°C < T <sub>a</sub> < 70°C	-	±0.7	-	mV/°C

Note: Dropout voltage is defined as the input voltage minus the output voltage that produces a 2% change in the output voltage from the value at V<sub>IN</sub> = V<sub>OUT</sub>+2V with a fixed load.

**TX7545Mxx, +4.5V Output Type**

Symbol	Parameter	Test Conditions		Min.	Typ.	Max.	Unit
		V <sub>IN</sub>	Conditions				
V <sub>OUT</sub>	Output Voltage	6.5V	I <sub>OUT</sub> =10mA	4.410	4.500	4.590	V
I <sub>OUT</sub>	Output Current	6.5V	-	120	150	-	mA
ΔV <sub>OUT</sub>	Load Regulation	6.5V	1mA ≤ I <sub>OUT</sub> ≤ 50mA	-	60	150	mV
V <sub>DIF</sub>	Voltage Drop(Note)	-	I <sub>OUT</sub> =1mA, ΔV <sub>OUT</sub> =2%	-	50	-	mV
I <sub>SS</sub>	Current Consumption	6.5V	No load	-	1.5	2.0	μA
$\frac{V_{OUT}}{V_{IN} - V_{OUT}}$	Line Regulation	-	5.5V ≤ V <sub>IN</sub> ≤ 16V I <sub>OUT</sub> =1mA	-	0.2	-	%/V
V <sub>IN</sub>	Input Voltage	-	-	-	-	15	V
$\frac{V_{OUT}}{T_a}$	Temperature Coefficient	6.5V	I <sub>OUT</sub> =10mA 0°C < T <sub>a</sub> < 70°C	-	±0.7	-	mV/°C

Note: Dropout voltage is defined as the input voltage minus the output voltage that produces a 2% change in the output voltage from the value at V<sub>IN</sub> = V<sub>OUT</sub>+2V with a fixed load.



**TX7550Mxx, +5.0V Output Type**

Symbol	Parameter	Test Conditions		Min.	Typ.	Max.	Unit
		V <sub>IN</sub>	Conditions				
V <sub>OUT</sub>	Output Voltage	7V	I <sub>OUT</sub> =10mA	4.9	5.00	5.1	V
I <sub>OUT</sub>	Output Current	7V	-	120	150	-	mA
ΔV <sub>OUT</sub>	Load Regulation	7V	1mA ≤ I <sub>OUT</sub> ≤ 50mA	-	60	150	mV
V <sub>DIF</sub>	Voltage Drop(Note)	-	I <sub>OUT</sub> =1mA, ΔV <sub>OUT</sub> =2%	-	50	-	mV
I <sub>SS</sub>	Current Consumption	7V	No load	-	1.5	2.0	μA
$\frac{V_{OUT}}{V_{IN} - V_{OUT}}$	Line Regulation	-	6V ≤ V <sub>IN</sub> ≤ 16V I <sub>OUT</sub> =1mA	-	0.2	-	%/V
V <sub>IN</sub>	Input Voltage	-	-	-	-	15	V
$\frac{V_{OUT}}{T_a}$	Temperature Coefficient	7V	I <sub>OUT</sub> =10mA 0°C < T <sub>a</sub> < 70°C	-	±0.75	-	mV/°C

Note: Dropout voltage is defined as the input voltage minus the output voltage that produces a 2% change in the output voltage from the value at V<sub>IN</sub> = V<sub>OUT</sub>+2V with a fixed load.

**TX7560Mxx, +6.0V Output Type**

Symbol	Parameter	Test Conditions		Min.	Typ.	Max.	Unit
		V <sub>IN</sub>	Conditions				
V <sub>OUT</sub>	Output Voltage	8V	I <sub>OUT</sub> =10mA	5.88	6.00	6.12	V
I <sub>OUT</sub>	Output Current	8V	-	120	150	-	mA
ΔV <sub>OUT</sub>	Load Regulation	8V	1mA ≤ I <sub>OUT</sub> ≤ 50mA	-	60	150	mV
V <sub>DIF</sub>	Voltage Drop(Note)	-	I <sub>OUT</sub> =1mA, ΔV <sub>OUT</sub> =2%	-	50	-	mV
I <sub>SS</sub>	Current Consumption	8V	No load	-	1.5	2.0	μA
$\frac{V_{OUT}}{V_{IN} - V_{OUT}}$	Line Regulation	-	7V ≤ V <sub>IN</sub> ≤ 16V I <sub>OUT</sub> =1mA	-	0.2	-	%/V
V <sub>IN</sub>	Input Voltage	-	-	-	-	15	V
$\frac{V_{OUT}}{T_a}$	Temperature Coefficient	8V	I <sub>OUT</sub> =10mA 0°C < T <sub>a</sub> < 70°C	-	±0.75	-	mV/°C

Note: Dropout voltage is defined as the input voltage minus the output voltage that produces a 2% change in the output voltage from the value at V<sub>IN</sub> = V<sub>OUT</sub>+2V with a fixed load.





## Typical Performance Characteristics

### (1) Output Voltage vs Input voltage

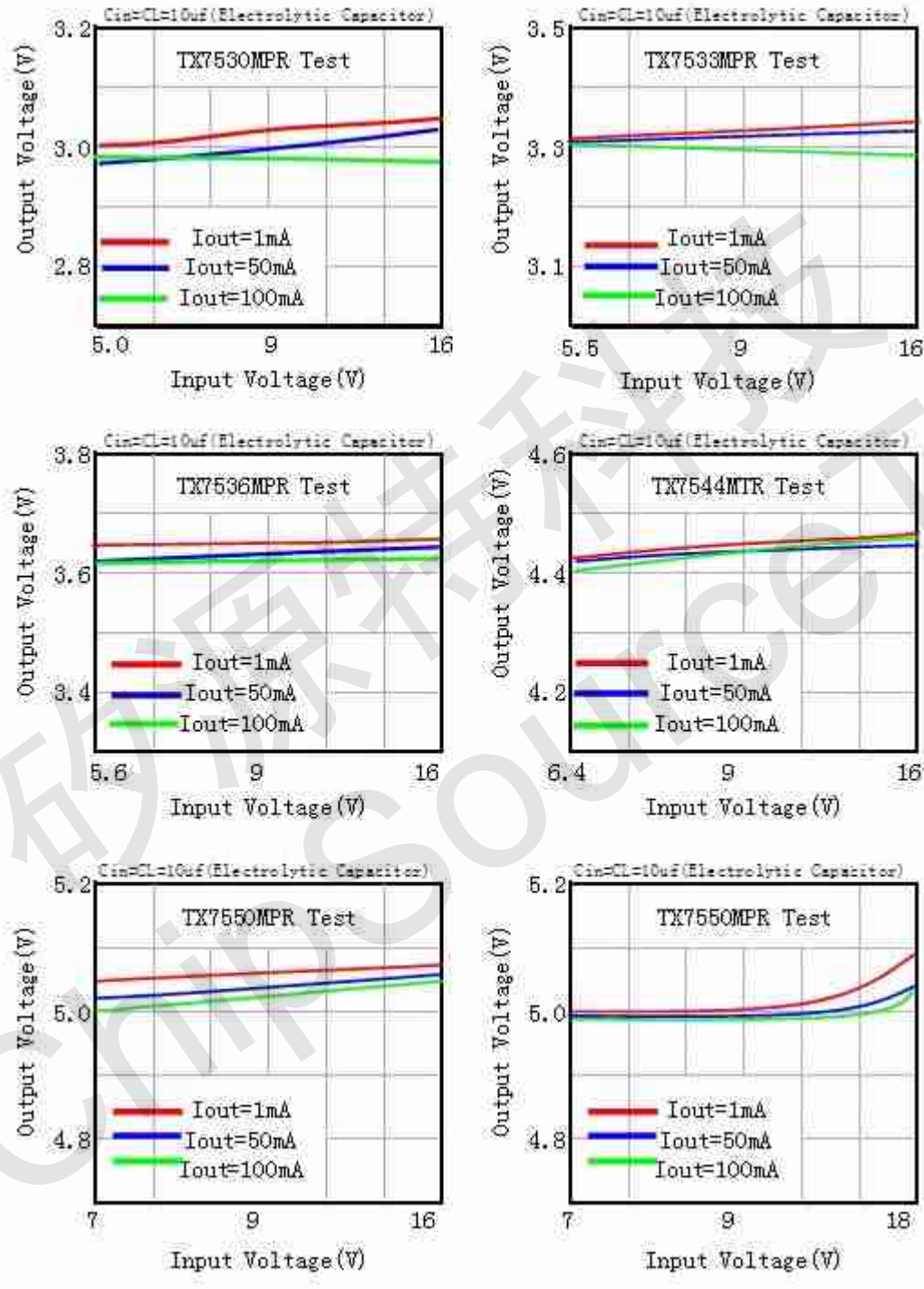



(2) Output Voltage vs. Output Current

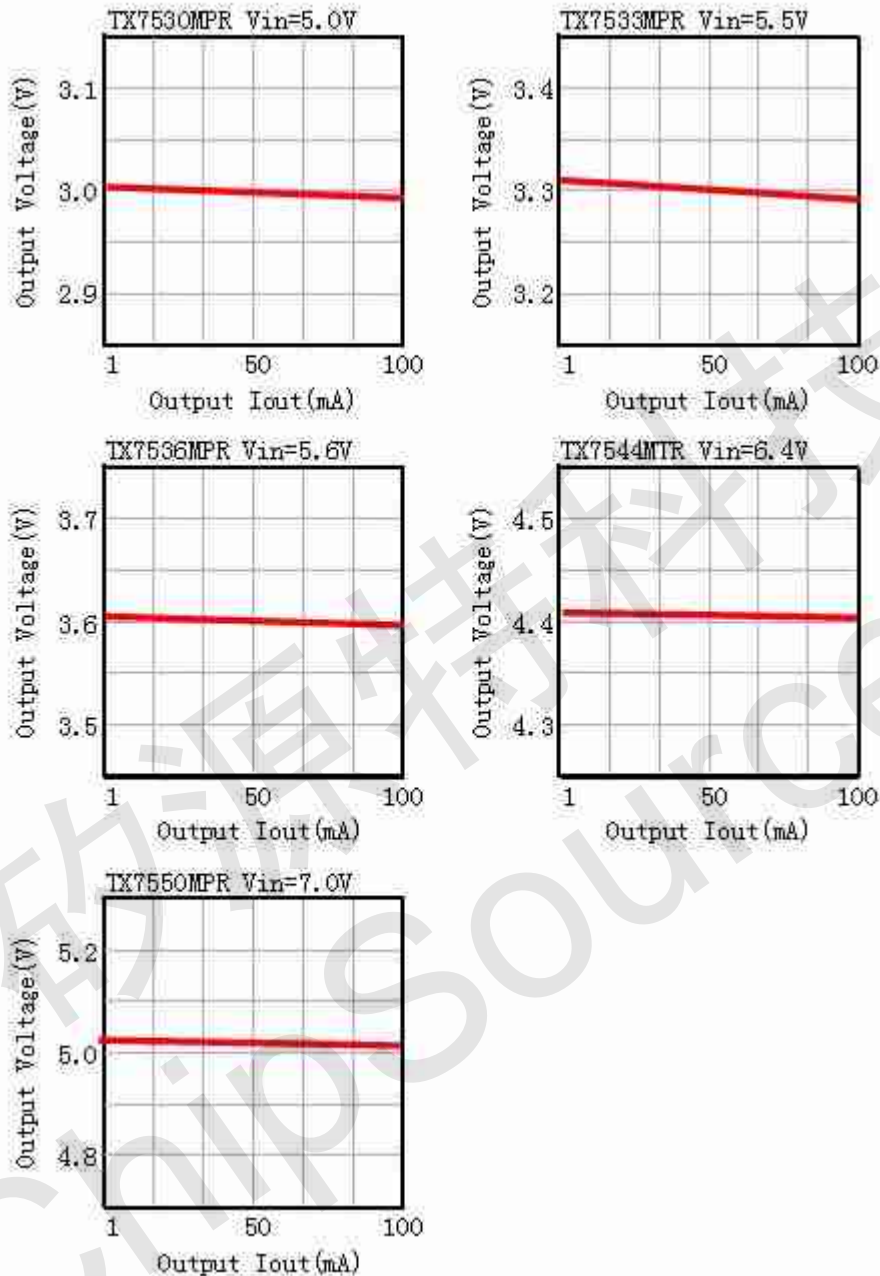



(3) Input Transient Response

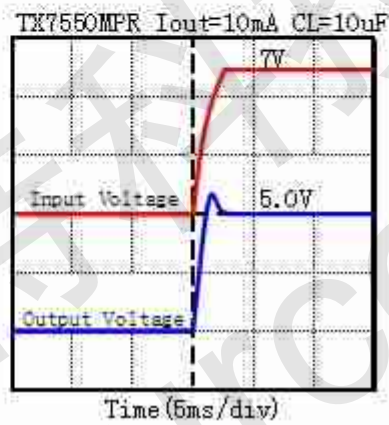
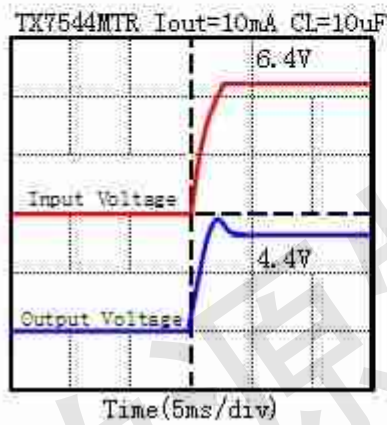
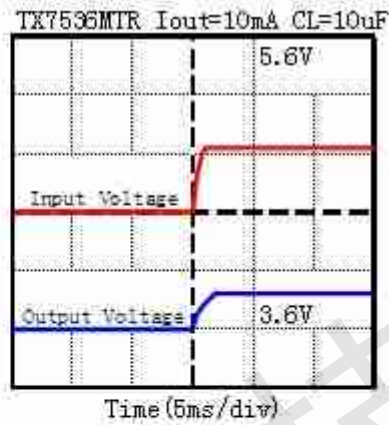
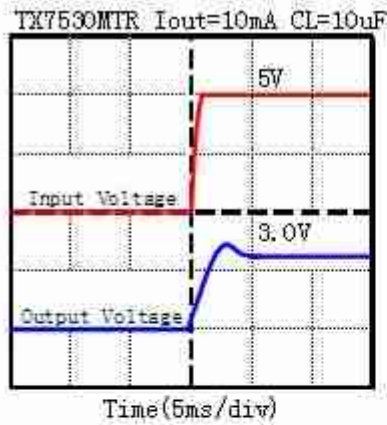

(4) Output Voltage vs. Ambient Temperature

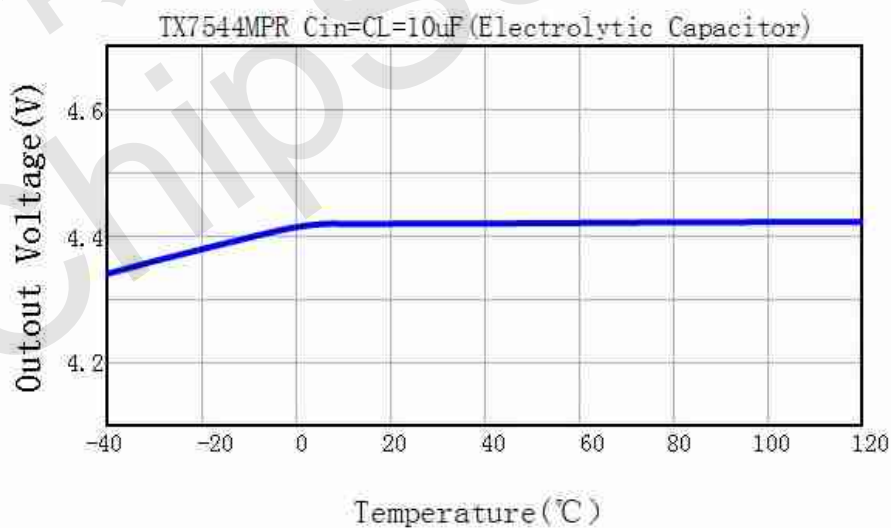

(5) MAX Output Current Vs. Input Voltage



TX7530MPR

Input Voltage	Max Output Current
5V	150mA
9V	150mA
12V	100mA
16V	60mA

TX7533MPR

Input Voltage	Max Output Current
5.3V	150mA
9V	150mA
12V	150mA
16V	100mA

TX7550MPR

Input Voltage	Max Output Current
7V	150mA
9V	150mA
12V	150mA
16V	100mA

Application Circuits  
Basic Circuits

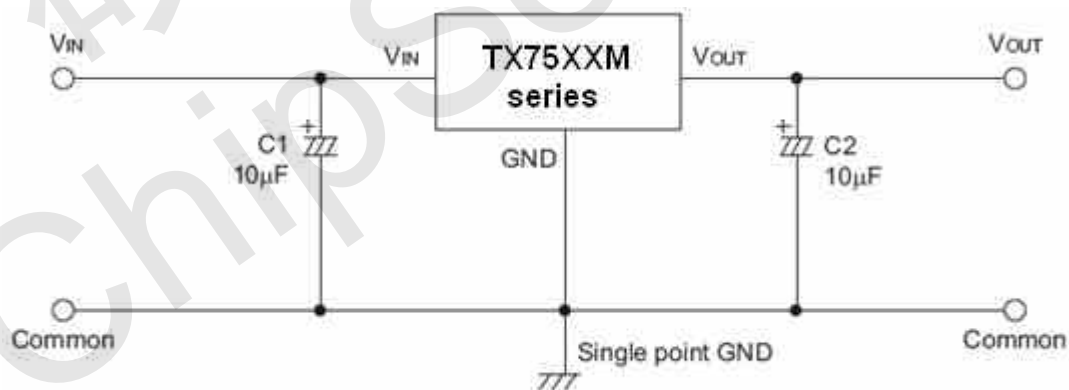



### High Output Current Positive Voltage Regulator

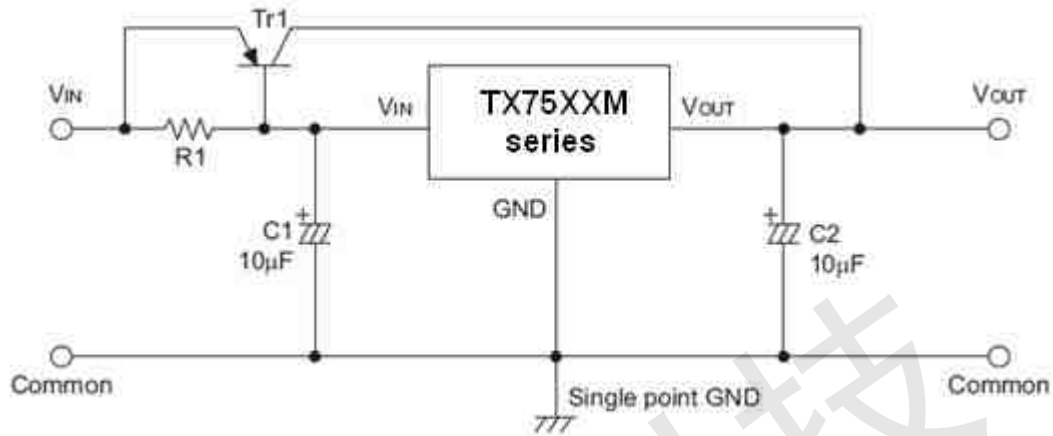

### Short-Circuit Protection by Tr1

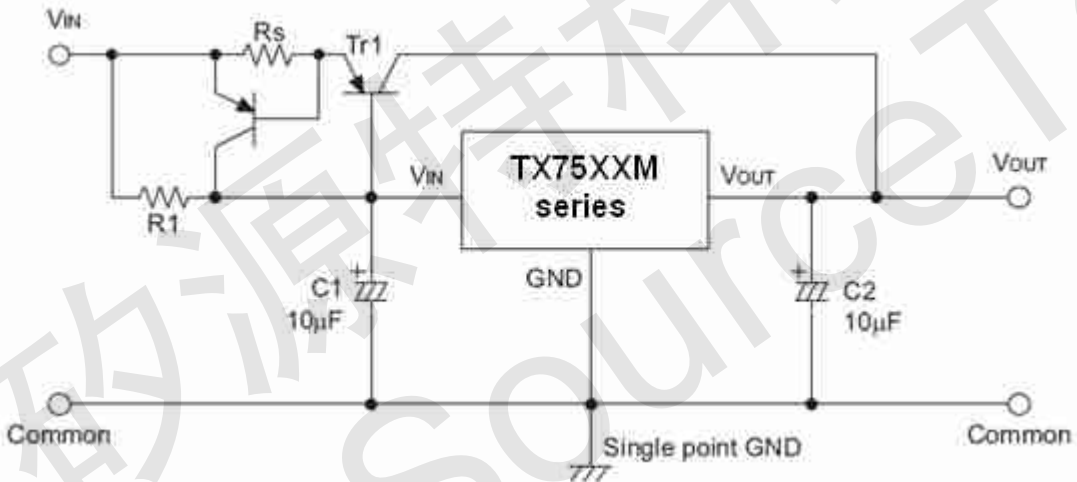

### Circuit for Increasing Output Voltage

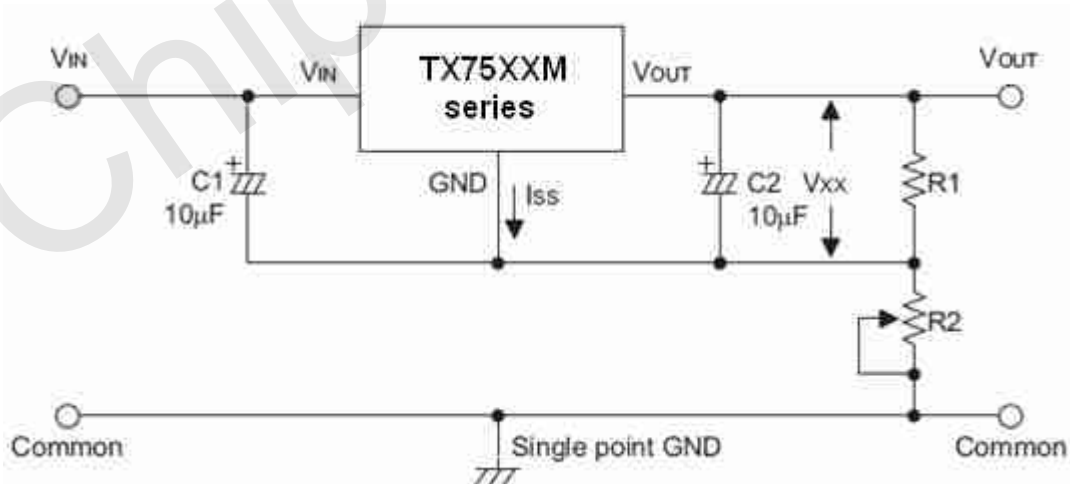



### Circuit for Increasing Output Voltage

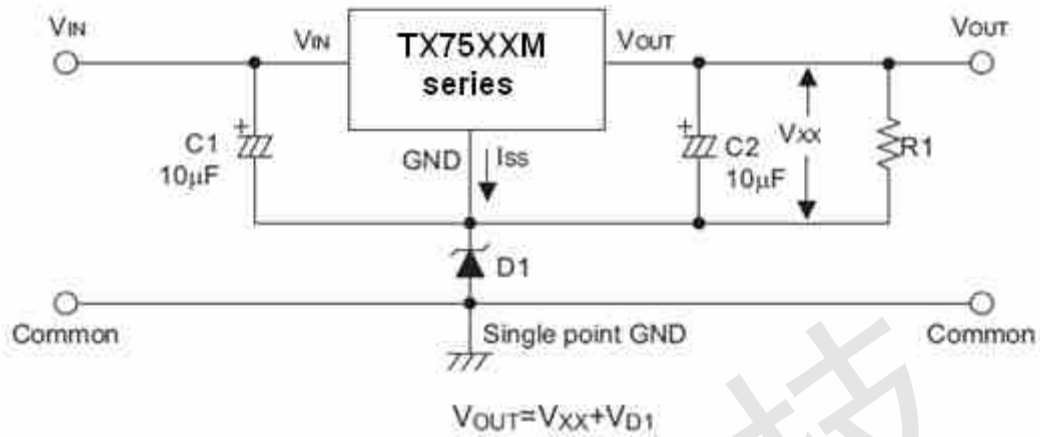

### Constant Current Regulator

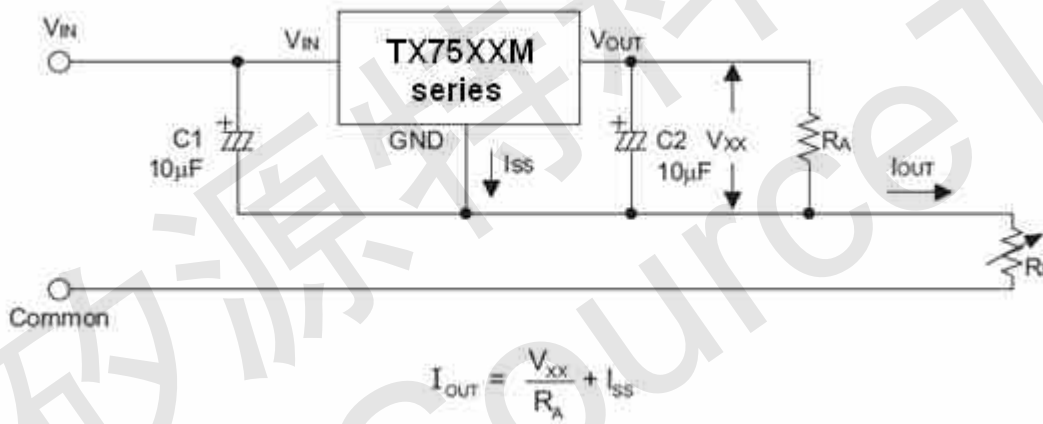

### Dual Supply

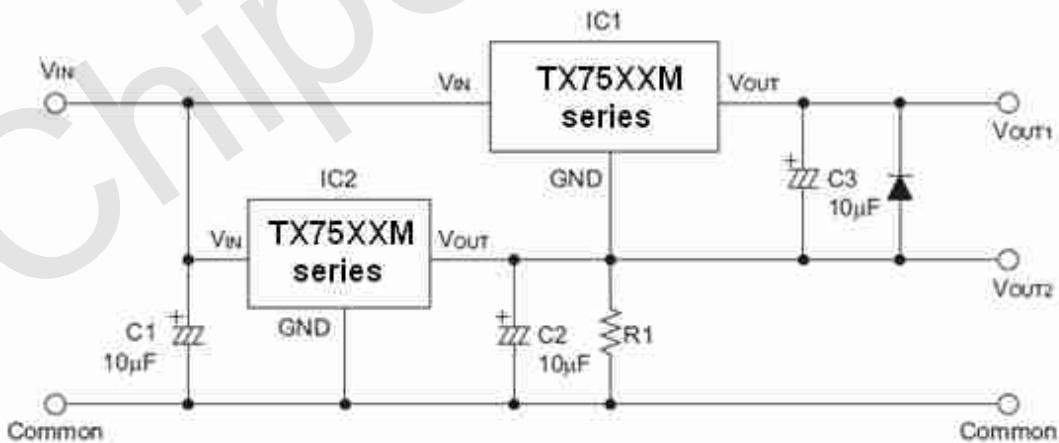



### Package Information 3-pin TO92 Outline Dimensions

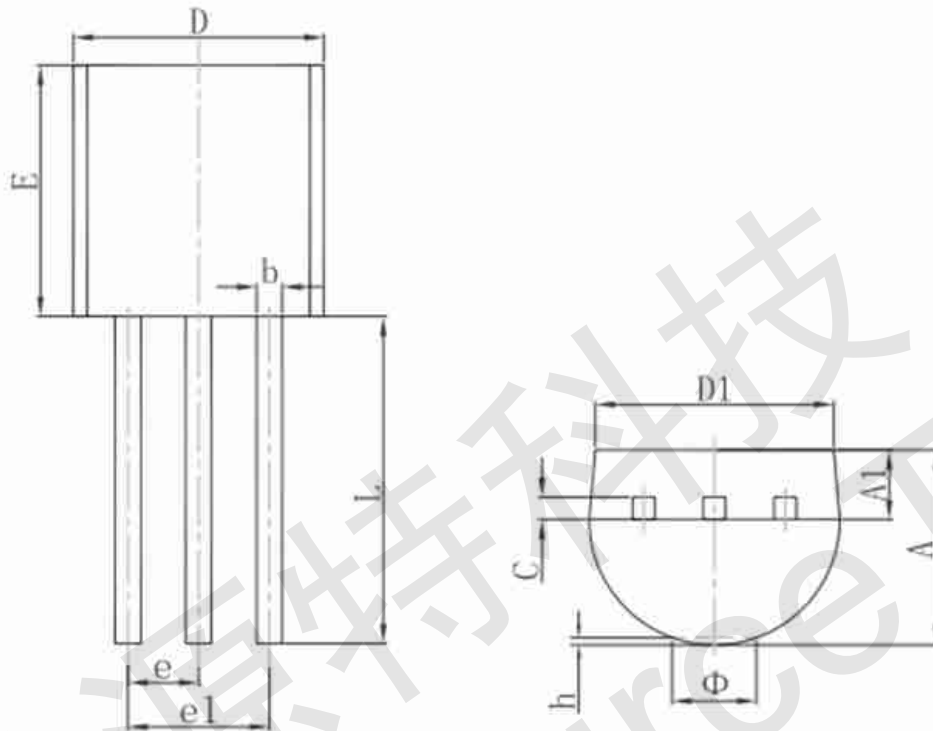

Symbol	Dimensions in Millimeters		Dimensions in Inches	
	Min.	Max.	Min.	Max.
A	3.300	3.700	0.130	0.146
A1	1.100	1.400	0.043	0.055
b	0.380	0.550	0.015	0.022
c	0.360	0.510	0.014	0.020
D	4.300	4.700	0.169	0.185
D1	3.430		0.135	
E	4.300	4.700	0.169	0.185
e	1.270 TYP.		0.050 TYP.	
e1	2.440	2.640	0.096	0.104
L	14.100	14.500	0.555	0.571
Φ		1.600		0.063
h	0.000	0.380	0.000	0.015



### 3-pin SOT89 Outline Dimensions

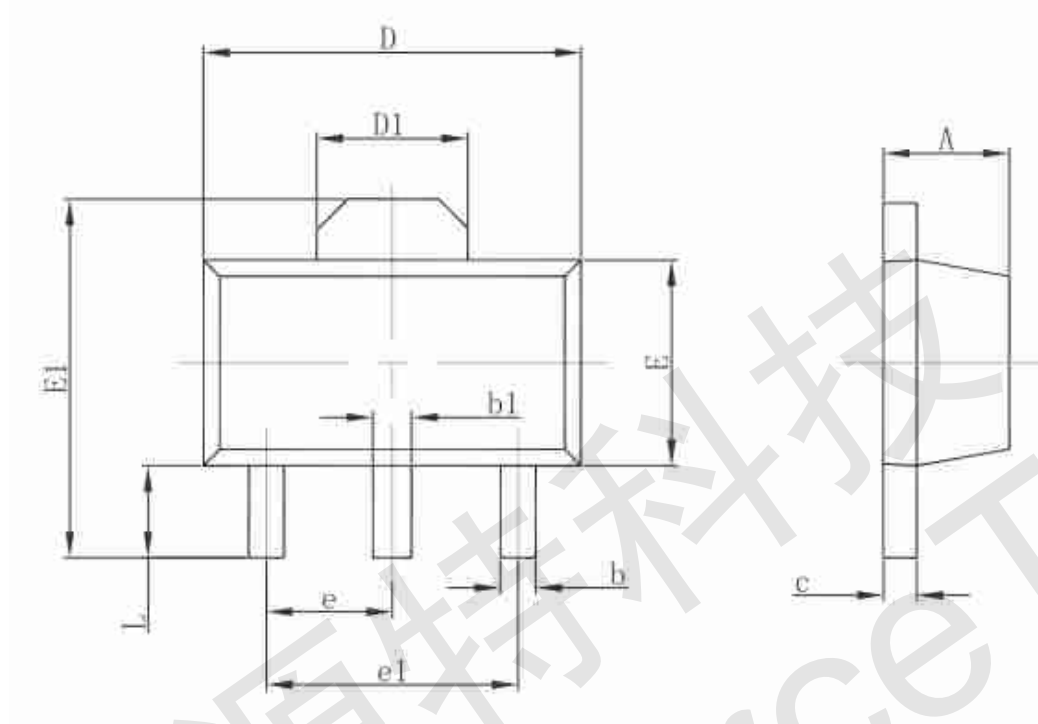

Symbol	Dimensions In Millimeters		Dimensions In Inches	
	Min.	Max.	Min.	Max.
A	1.400	1.600	0.055	0.063
b	0.320	0.520	0.013	0.020
b1	0.400	0.580	0.016	0.023
c	0.350	0.440	0.014	0.017
D	4.400	4.600	0.173	0.181
D1	1.550 REF.		0.061 REF.	
E	2.300	2.600	0.091	0.102
E1	3.940	4.250	0.155	0.167
e	1.500 TYP.		0.060 TYP.	
e1	3.000 TYP.		0.118 TYP.	
L	0.900	1.200	0.035	0.047





### 3-pin SOT23-3 Outline Dimensions

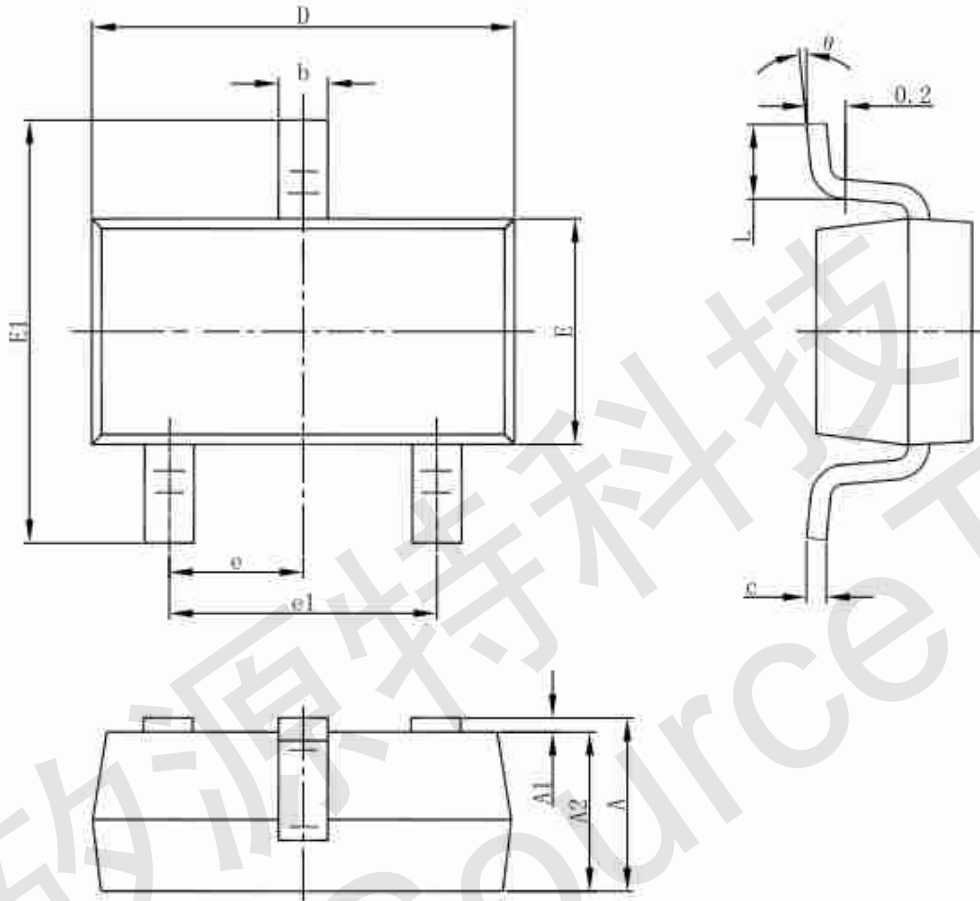

Symbol	Dimensions In Millimeters		Dimensions In Inches	
	Min	Max	Min	Max
A	1.050	1.250	0.041	0.049
A1	0.000	0.100	0.000	0.004
A2	1.050	1.150	0.041	0.045
b	0.300	0.500	0.012	0.020
c	0.100	0.200	0.004	0.008
D	2.820	3.020	0.111	0.119
E	1.500	1.700	0.059	0.067
E1	2.650	2.950	0.104	0.116
e	0.950(BSC)		0.037(BSC)	
e1	1.800	2.000	0.071	0.079
L	0.300	0.600	0.012	0.024
$\theta$	0°	8°	0°	8°



### 3-pin SOT23 Outline Dimensions

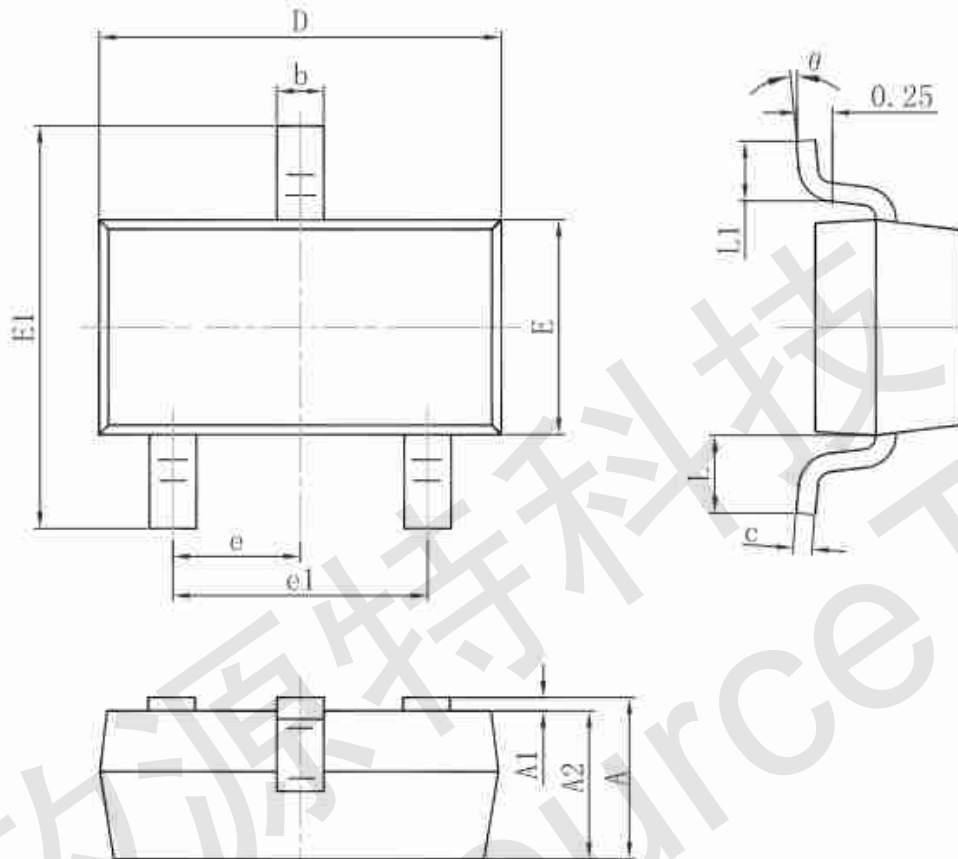

Symbol	Dimensions In Millimeters		Dimensions In Inches	
	Min.	Max.	Min.	Max.
A	0.900	1.150	0.035	0.045
A1	0.000	0.100	0.000	0.004
A2	0.900	1.050	0.035	0.041
b	0.300	0.500	0.012	0.020
c	0.080	0.150	0.003	0.006
D	2.800	3.000	0.110	0.118
E	1.200	1.400	0.047	0.055
E1	2.250	2.550	0.089	0.100
e	0.950 TYP.		0.037 TYP.	
e1	1.800	2.000	0.071	0.079
L	0.550 REF.		0.022 REF.	
L1	0.300	0.500	0.012	0.020
$\theta$	0°	8°	0°	8°